

Note to ATSRAC Members: The following presentation minus pictures was given at the 2001 EMMC Forum in Dallas. The context of this presentation was to offer ideas to operators as to what they can be doing now toward enhancing their electrical systems maintenance programs.

***Getting Prepared
For Aging Systems***

Enhance Knowledge Across Your Organization

What Vehicles will reach your key personnel:

Videos?

Classroom Training?

Broadcast Alerts?

Newsletters?

Crew Meetings?

Northwest Airlines Chose:

**Video - ATA's Spec 117 Video
and
Classroom Training**

**All Heavy Maintenance Mechanics,
Cleaners, and Inspectors are being trained**

Maintenance Personnel were encouraged to raise concern areas to Engineering at the completion of the classroom training

Two Examples of Feedback from Maintenance Personnel After Training

Inspector Identified Added Wiring Run That Was Too Close To Attach Hardware

DC9 Electrical Power Center (EPC)

R&E Mechanics Reported Seeing Evidence of Arcing in Power Feeder Cable System

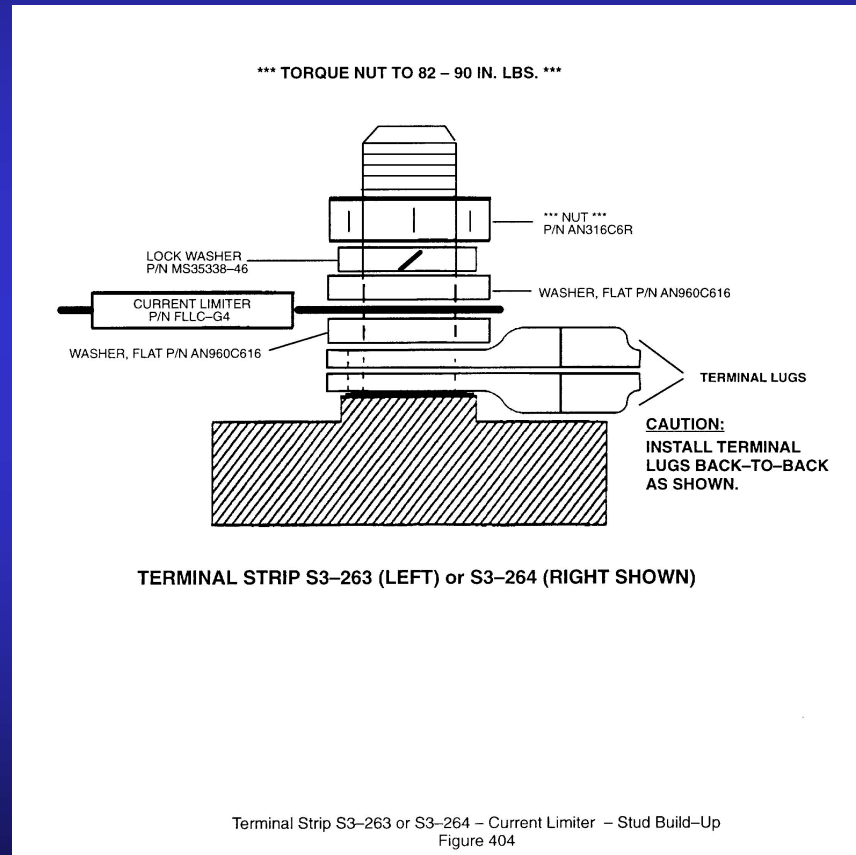
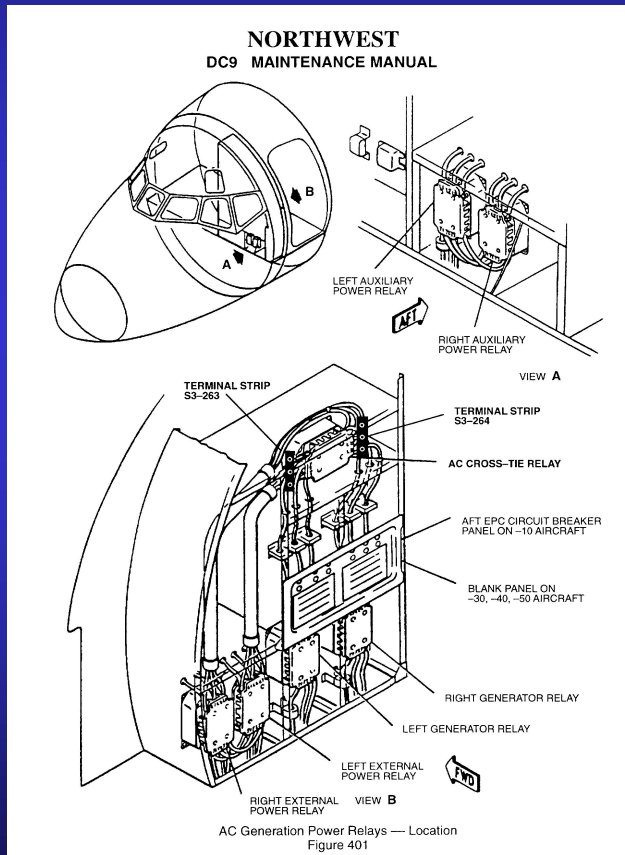

NWA Analyzes Smoke/Fume/Odor Operational Reports Differently Now

- Investigate Every Smoke/Fume/Odor Report.**
- Identify Probable Cause.**
- If prior event history, detail Engineering study.**
- If One Off Event, assess from a Systemic perspective...is it likely that other aircraft may exhibit the same problem?**

As a result of deeper review of NWA's Operational Events

- Issued Fleet Campaign to insure DC9
Autospoiler Actuator Covers were installed**
- In Flight Issued Points of Emphasis to not
store paper/plastic items in ovens**

Review Candidate Alert Service Bulletins Identified by ATSRAC Task 2

- Wiring Related Service Bulletins have been Identified as candidates for Alert Status Future ADs on 727, 737, 747 Classic, DC8, DC9, DC10, L1011, and A300**
- Many are in the rulemaking process and if not they soon will be**
- Lists are available through your OEM or in ATSRAC Task 2 Final Report**

Start Using Guidelines from ATSRAC

Task 3 Maintenance Criteria

In an aircraft maintenance program

- **Use an Enhanced Zonal Analysis Procedure approach to inspect wire systems in a zone**

This examines what hazards exist in the zone that could contribute to premature degradation of the wiring

Northwest DC9 E&E Bay Zone Assessment

Assess the maintenance tasks needed to adequately protect wiring in the zone from:

- Galley and Lavatory Potable Water Lines**
- Galley and Lavatory Drainage Lines**
- Cockpit Floor Drainage Systems**
- Entry Door Sill Drain Systems**
- CPCP Compound Overspray Potential**

Northwest DC9 E&E Bay Zone Assessment

End Work Card Product will transform from “check wiring” to:

Examine wiring in the vicinity of lavatory drain line for evidence of drain fluid contamination. If contamination is found remove contaminants per SPWM. Check and repair source of drainage system leak.

Examine Wiring Repair and Installation Tools

Do you stock correct manufacturers tooling for all wire types and sizes?

What type of splices do you carry? All environmental type? What restrictions on their use do you have?

Most important how good is your wiring repair and installation documentation?

Encourage Voluntary Activity To Get Started

- **Prepare your maintenance technicians**
- **In depth looks at any smoke/fume/odor reports**
- **Review expected ADs on your Fleet**
- **Consider enhancing zonal wiring inspections**
- **Assess Tools and Repair Materials**