

# Bending of Straight Copper Terminals

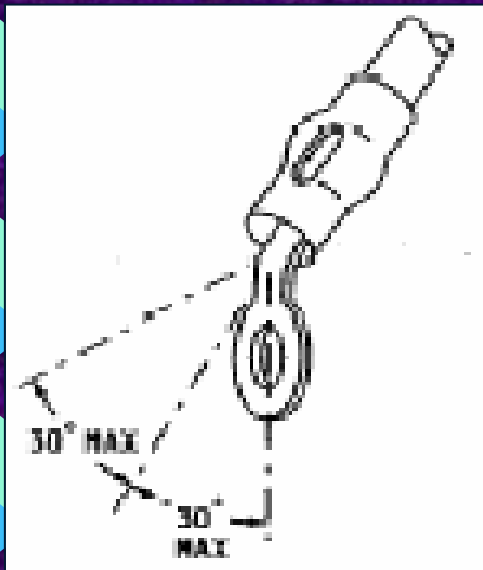

Brazed joint

Position of tongue before bending

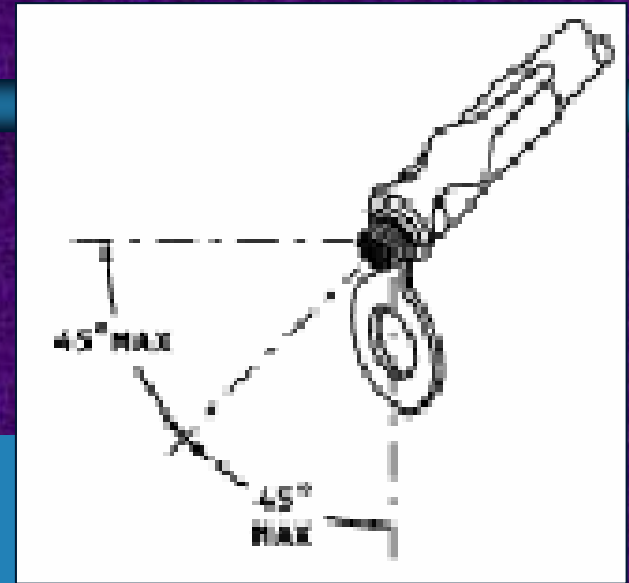
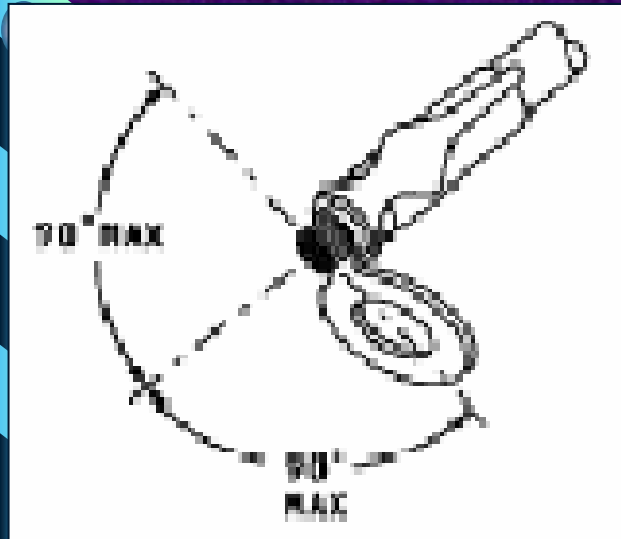
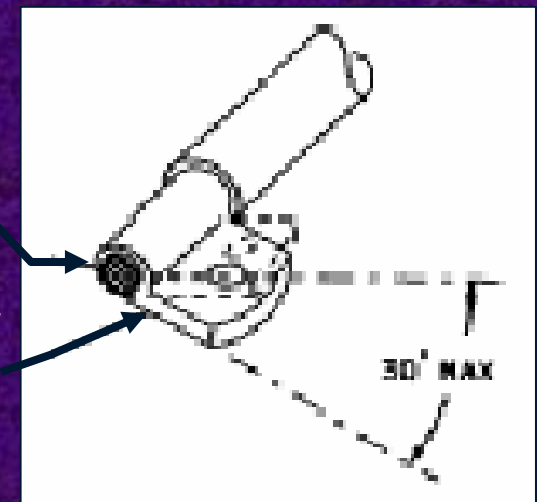



# Terminal Strips

---

- Barriers to prevent adjacent studs from contacting each other
- Current should be carried by terminal contact surface and not by stud
- Studs anchored against rotation
- Replace defective studs with studs of same size and material, mount securely, tighten terminal securing nut

# Terminal Strips, cont.

- **Mount strips so loose metallic objects cannot fall across terminal**
  - **Provide spare stud for breaks and future expansion**
  - **Inspect terminal periodically for loose connections, metallic objects, dirt, and grease accumulation**
    - **Can cause arcing, resulting in fire or systems failure**

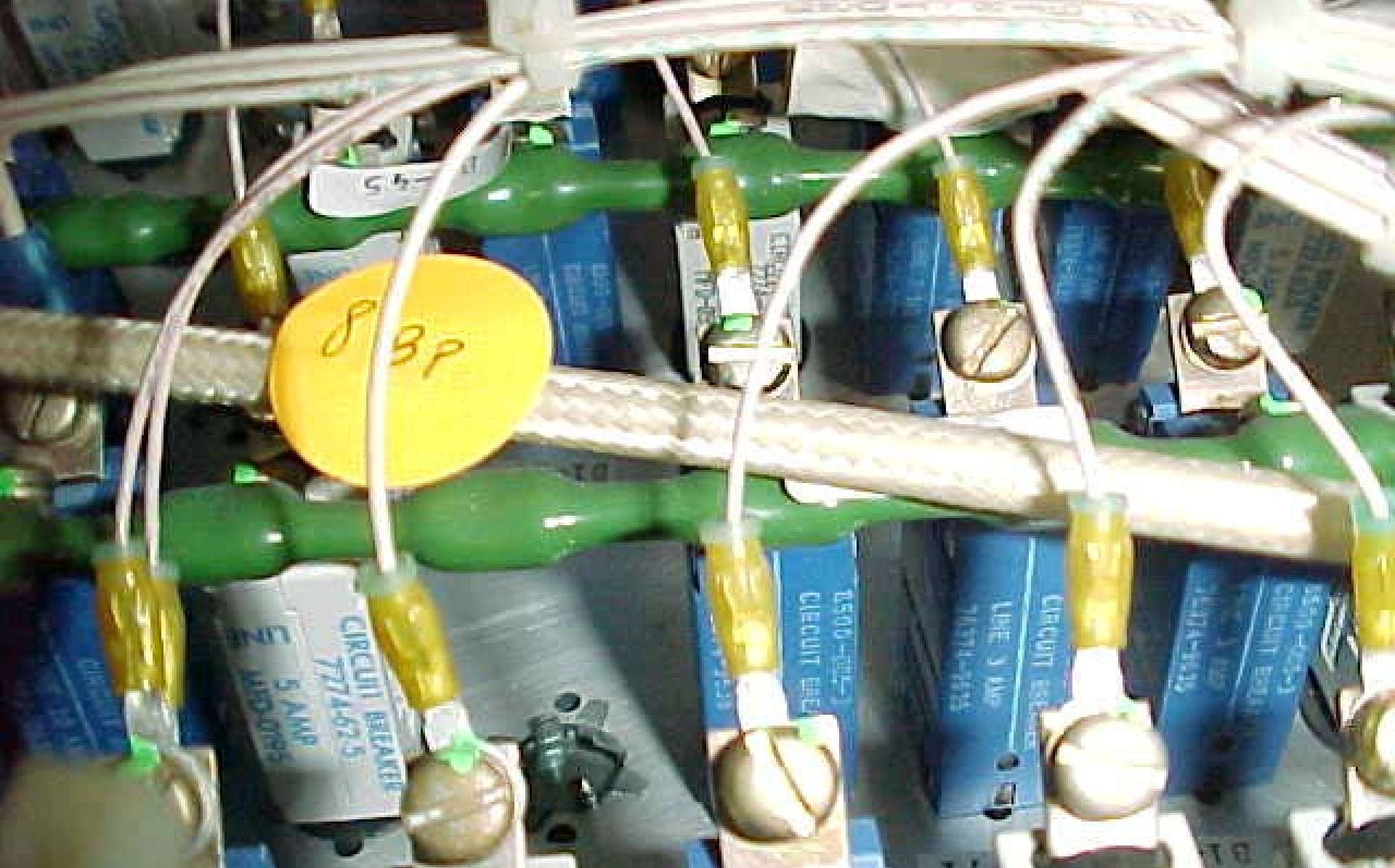

**Terminals on circuit breakers**



**Power feeder terminals**



# Terminal Lugs

---

- ➔ **Connect wiring to terminal block studs**
- ➔ **No more than 4 lugs, or 3 lugs and a bus bar, per stud**
- ➔ **Lug hole size should match stud diameter**
  - **Greatest diameter on bottom, smallest on top**
  - **Tightening terminal connections should not deform lugs**

# Terminal Lugs, cont.

## → Aluminum lugs

- Crimped to aluminum wire only
  - Special attention needed to guard against excessive voltage drop at terminal junction
    - Inadequate terminal contact area
    - Stacking errors
    - Improper torquing
- Use calibrated crimp tools

# Terminal Stacking (like materials)

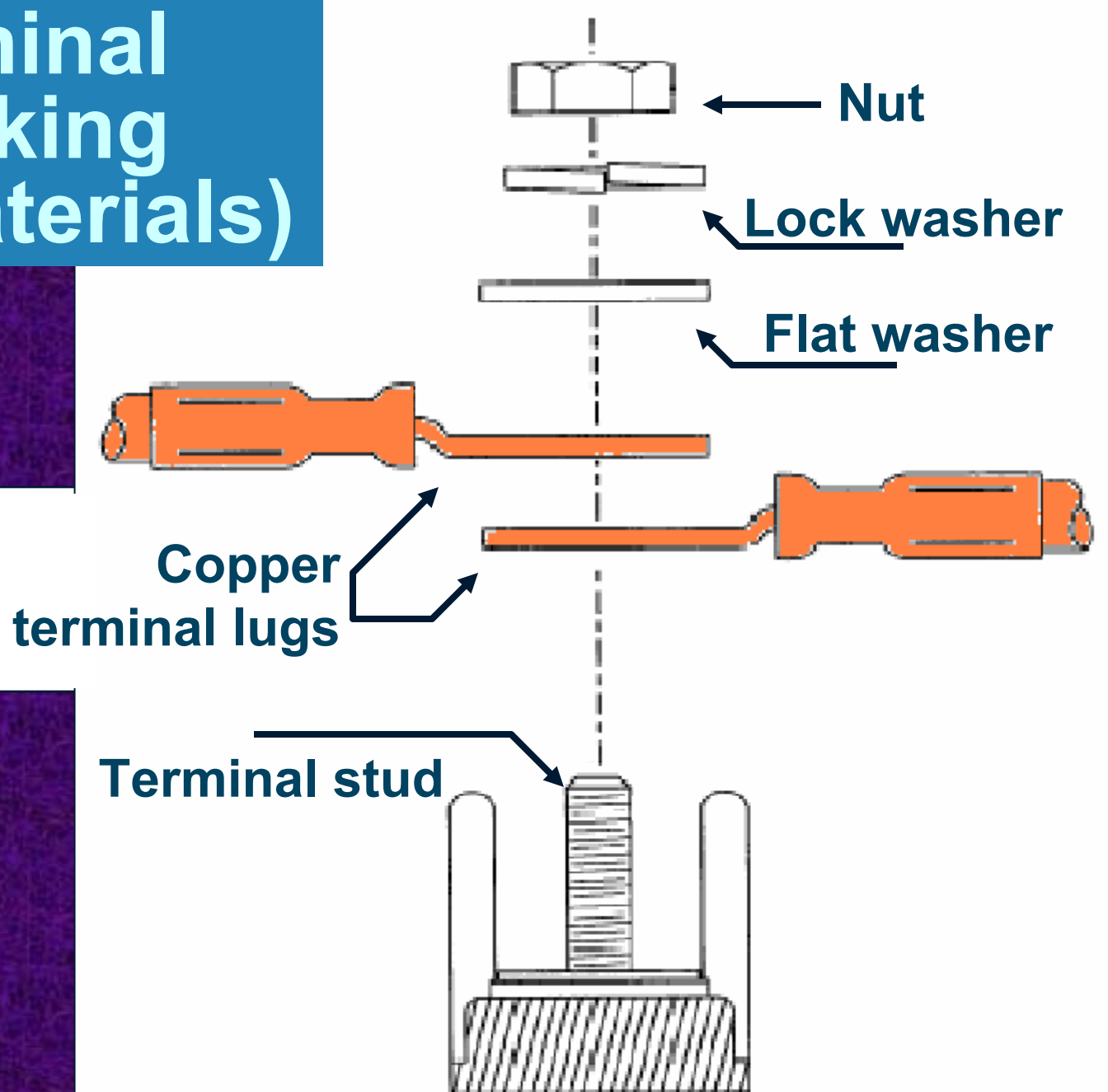

# Terminal Stacking (unlike materials)

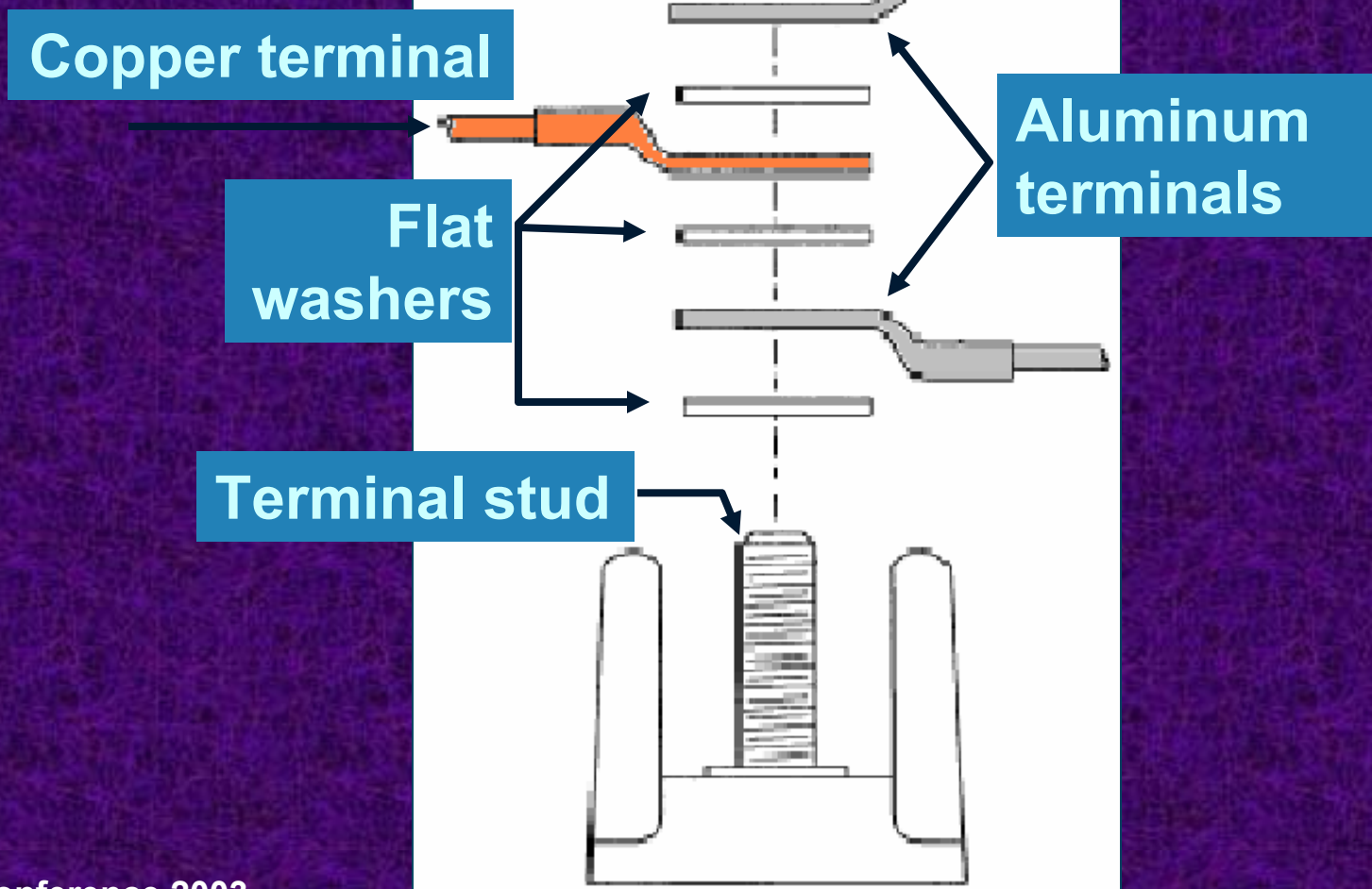

# Terminal Stacking Methods

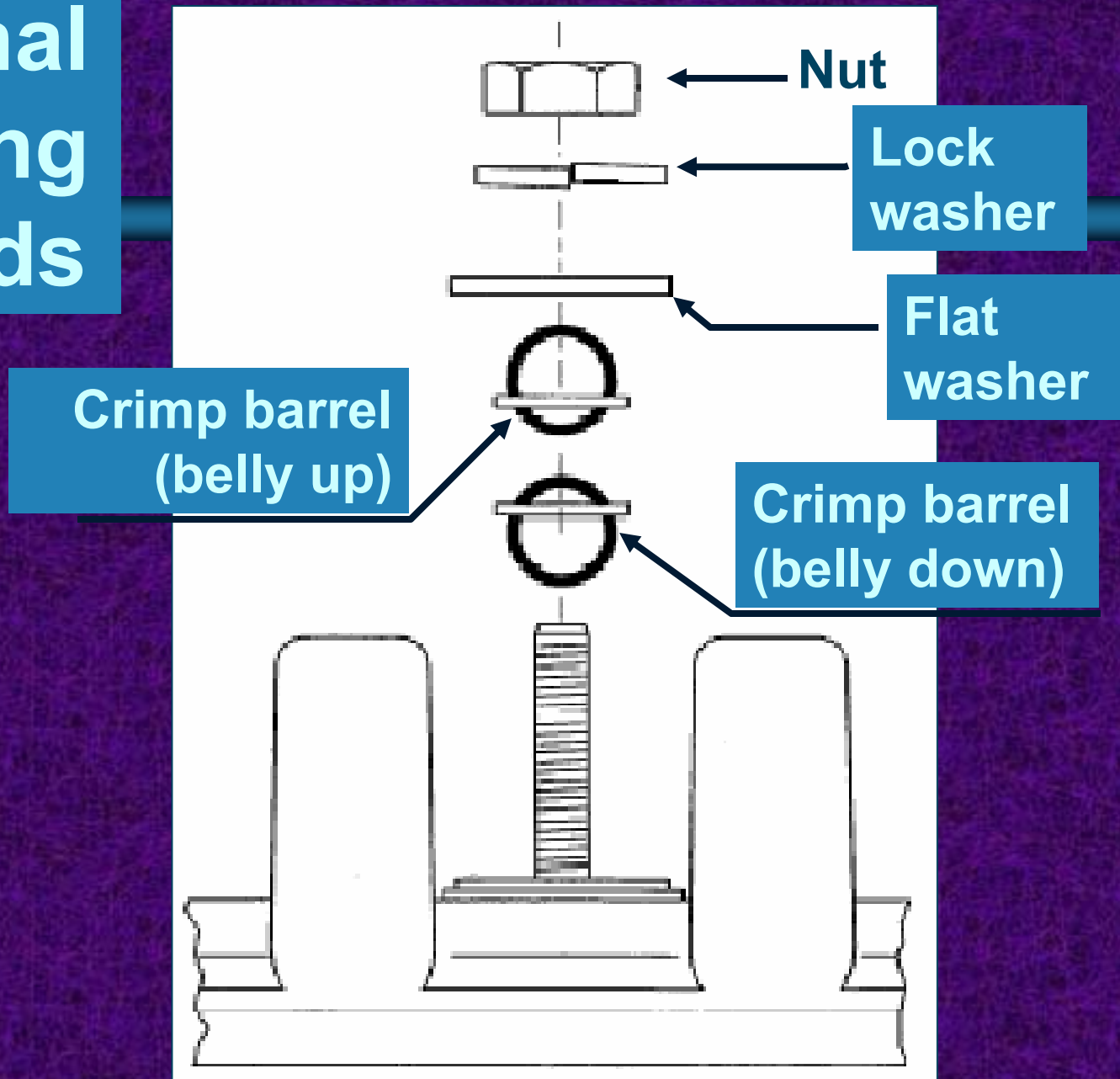

## One-Sided Entry With Two Terminals

# Terminal Stacking Methods, cont.

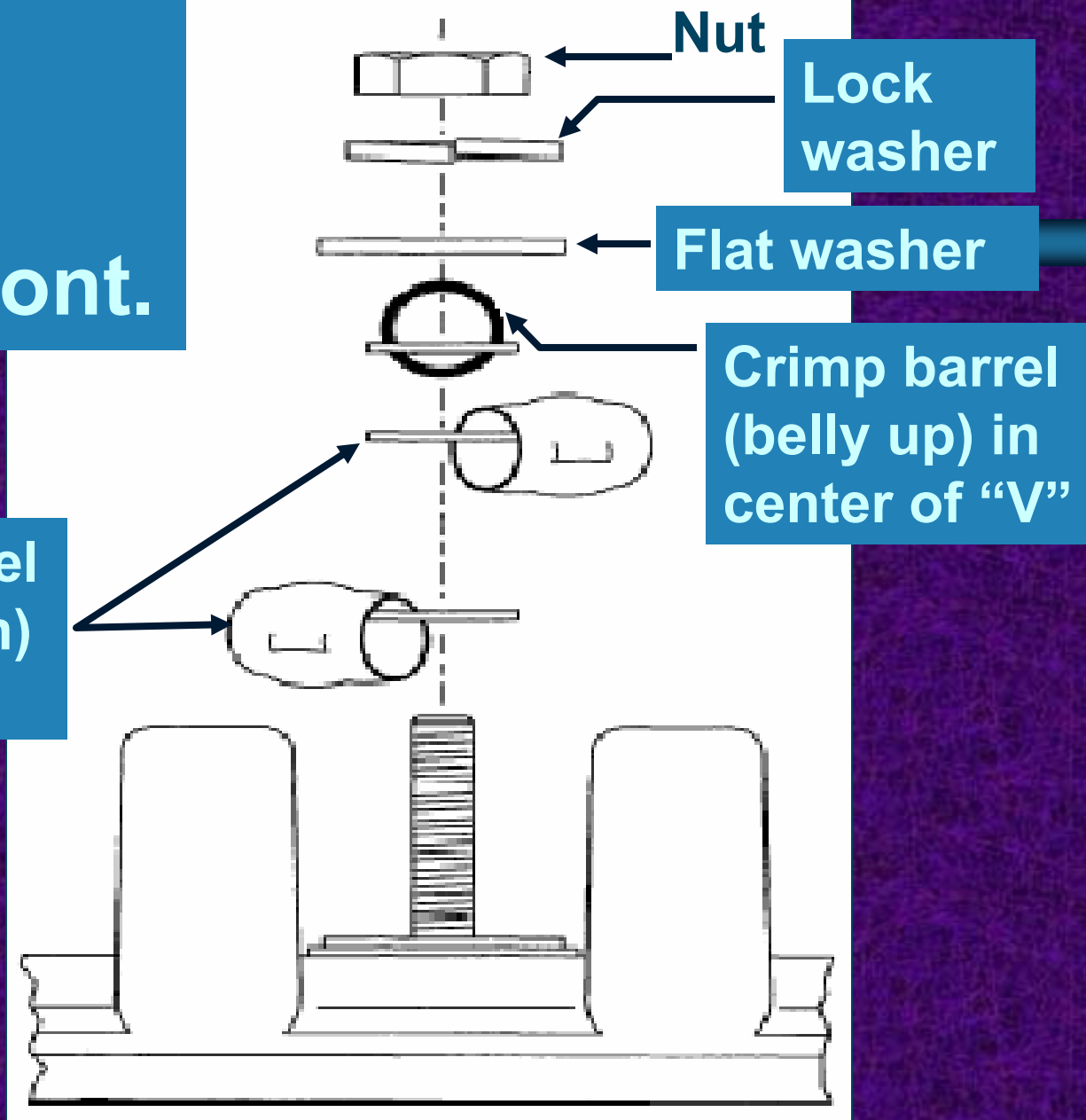

Crimp barrel (belly down) in "V" split

Crimp barrel (belly up) in center of "V"

## One-Sided Entry With 3 Terminals

# Terminal Stacking Methods, cont.

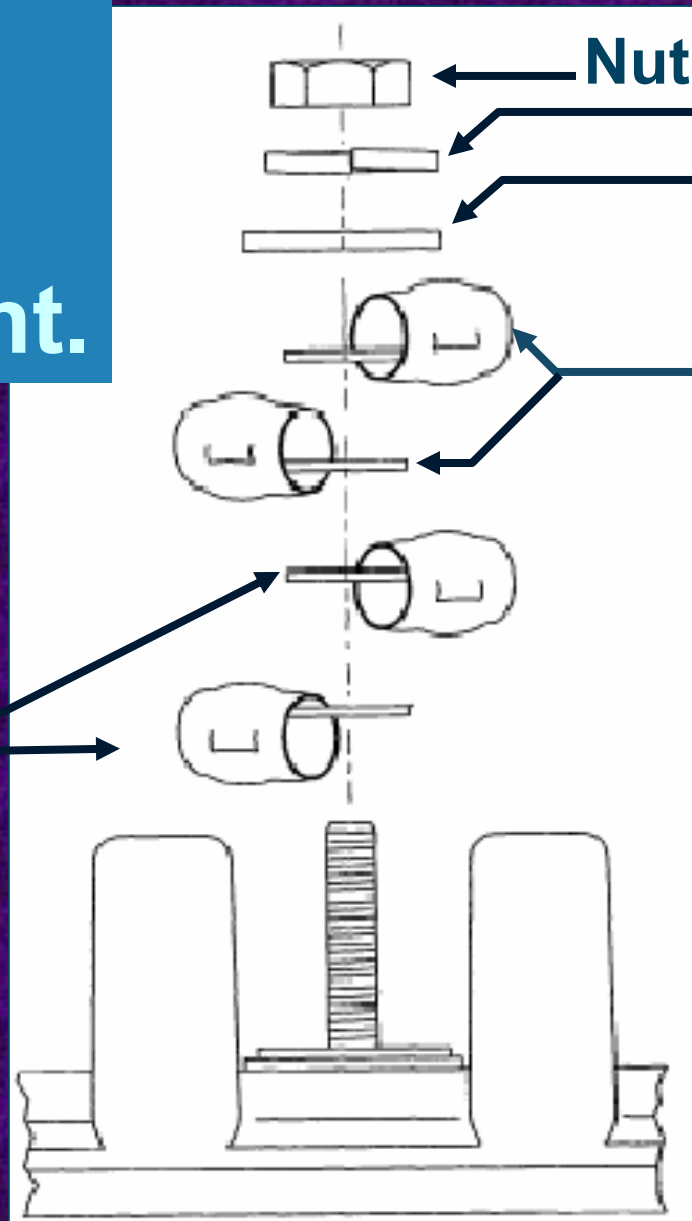

**Nut**

**Lock washer**

**Flat washer**

**Crimp barrel (belly up) in "V" split**

**Crimp barrel (belly down) in "V" split**

## One-Sided Entry With 4 Terminals

# Terminal Tightening Hardware

**Incorrect**

Space

Nut

Lock washer  
Flat washer

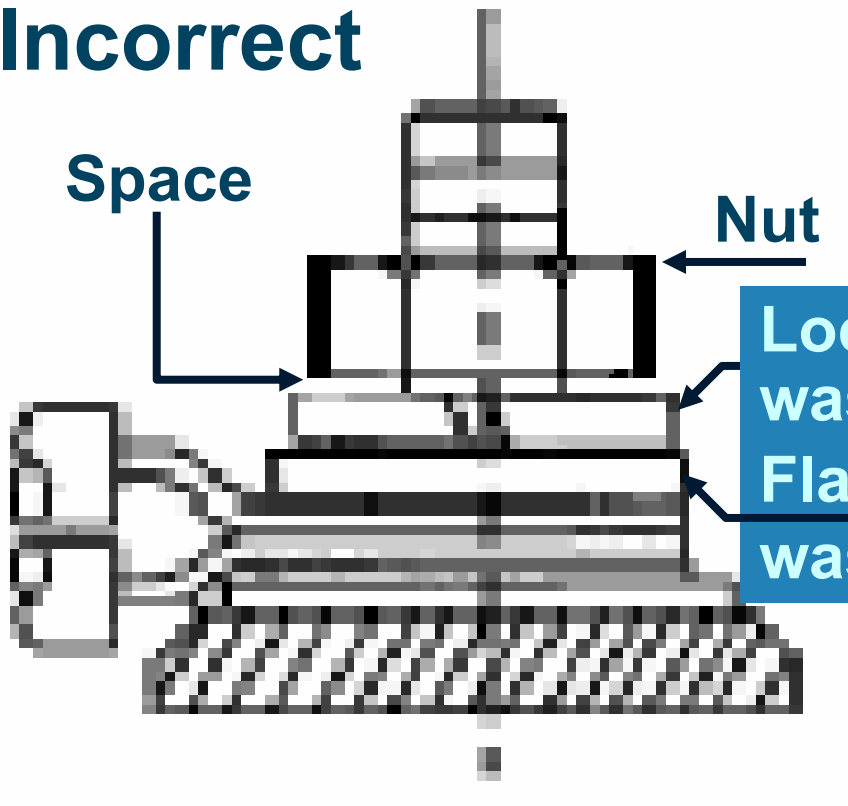

**Correct**

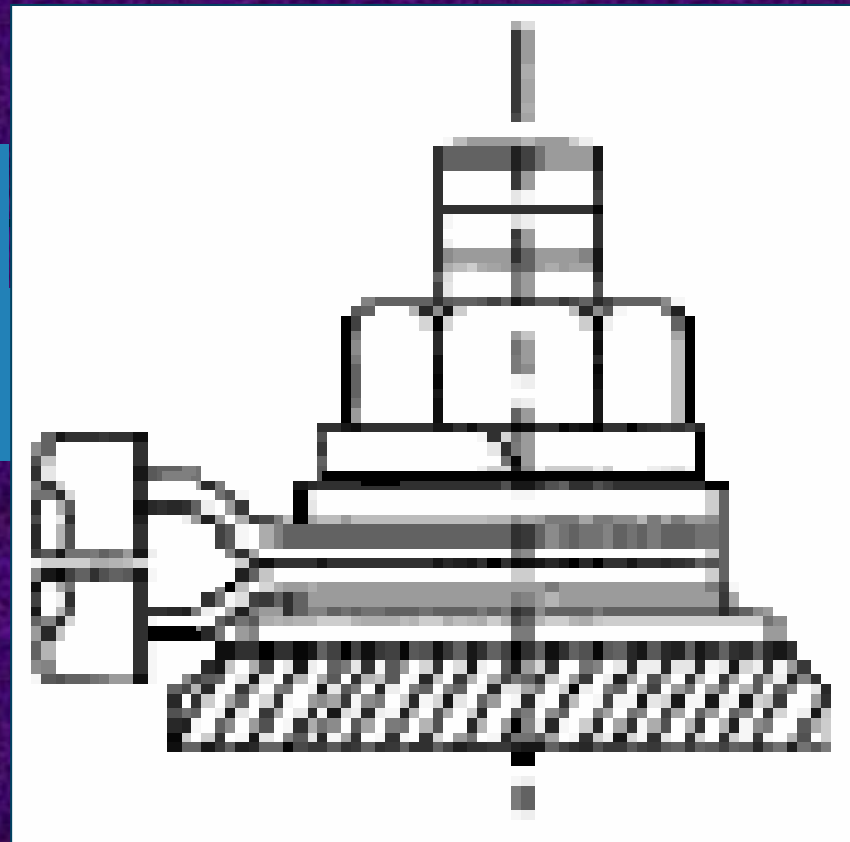

**Lock washer  
not compressed**

**Lock washer compressed**

# Washer Size Selection

Improperly-sized washer

Raised portion of terminal

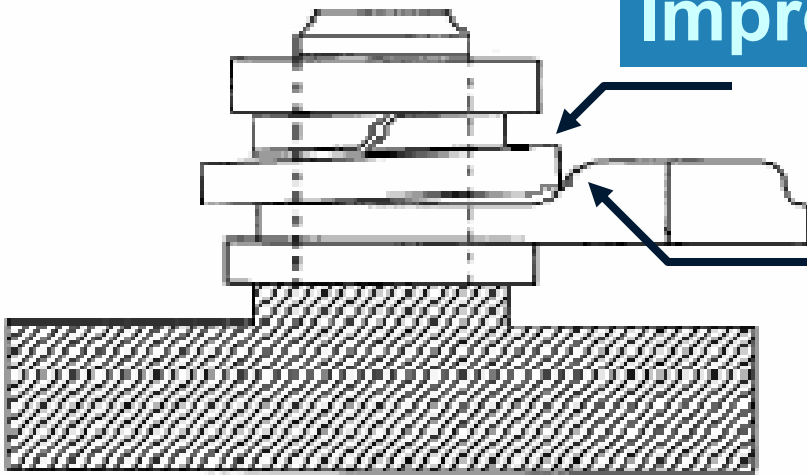

Split lock washer

Non-self locking nut

Steel washers

Aluminum terminal

**Correct**

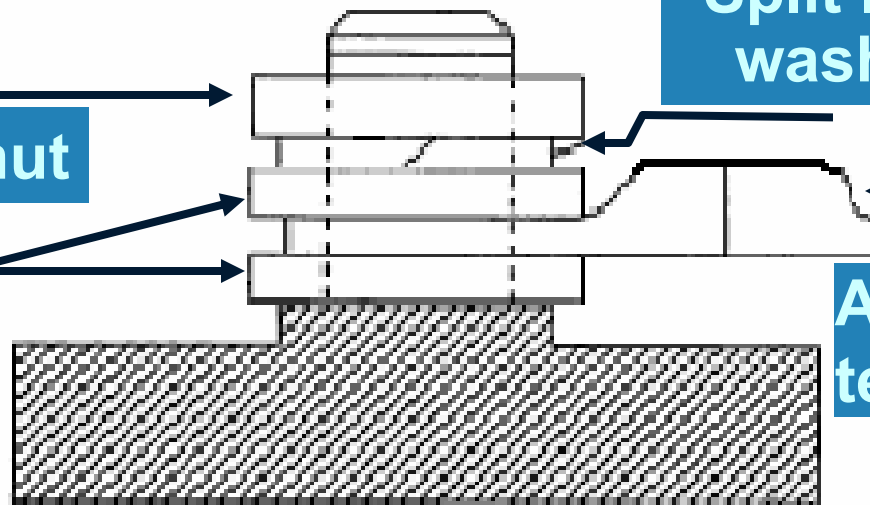

# Example: Terminal Stacking

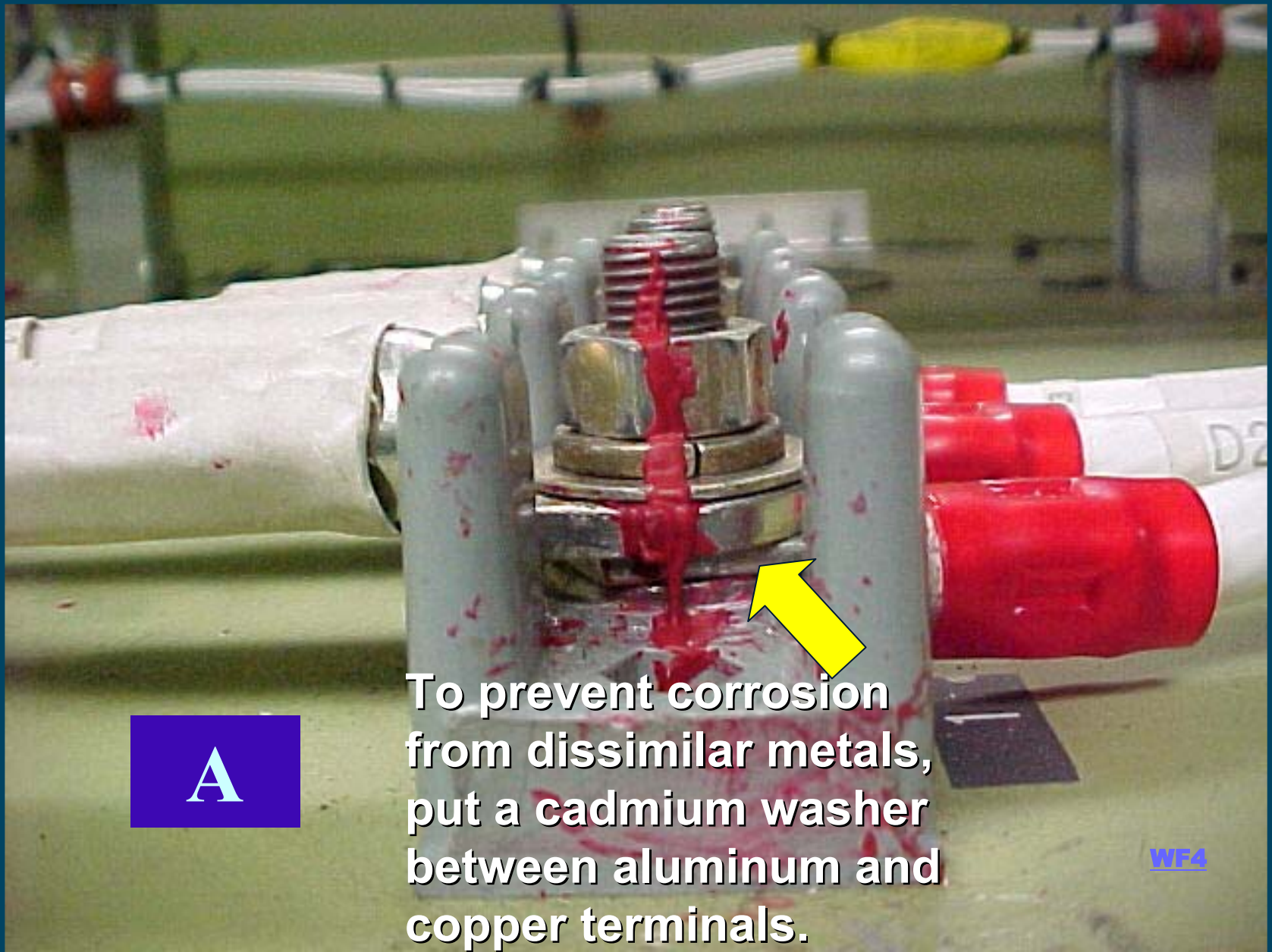

A

To prevent corrosion from dissimilar metals, put a cadmium washer between aluminum and copper terminals.

[WF4](#)